



Gooch & Housego



OL 100 Solar Constant Irradiance Standard

General

The OL 100 is a high-intensity standard consisting of a 1000-watt, DXW, tungsten-halogen lamp mounted in a slip-cast, fused silica reflector. The source has an effective radiating area of 3 x 5 cm. At a distance of 40 cm, the total irradiance is on the order of one solar constant (approximately 136 mW/cm²). Uniformity tests performed on a number of these units show that the irradiance in the specified direction over an area of 4 cm² is uniform to ± 0.25%.

The standards can be obtained with calibrations for total irradiance, spectral irradiance and illuminance. All calibrations are based on standards supplied by the National Institute of Standards and Technology (NIST).

The following table lists the type of calibrations available and their corresponding model number:

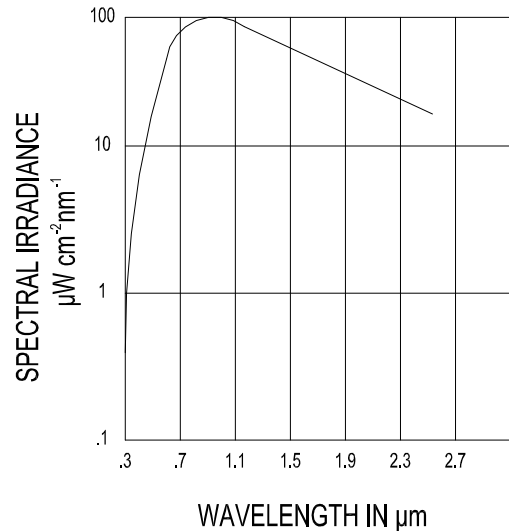

Type of Calibration

Model

Spectral Irradiance (300 – 750 nm)	100A
Spectral Irradiance (750 – 2500 nm)	100B
Spectral Irradiance (300 – 2500 nm)	100C
Total Irradiance	100D
Total and Spectral (300 – 2500 nm)	100H
Illuminance Only *	100P
Uncalibrated (seasoned)	100U

** For illuminance calibrations in addition to the above calibrations, add the suffix "P" to the appropriate model number*

Contact: sales@goochandhousego.com

www.goochandhousego.com

As part of our policy of continuous product improvement, we reserve the right to change specifications at any time

Specifications

Total Irradiance (nominal)	136 mW/cm ²
Nominal Irradiance at 1000 nm	100μW/cm ² nm
Illuminance (nominal)	3 lumens/cm ² (3000 fc)
Long Term Stability	0.06% / hour
Uncertainty*	
Spectral Irradiance	± 1 to 2%
Total Irradiance	± 1.5%
Illuminance	± 1.5%

* Relative to NIST Standards

Method of Calibration

The instrumentation and technique used by Gooch and Housego to transfer calibrations from a standard of spectral irradiance to an uncalibrated lamp is patterned after that used at NIST. The measurement procedure employs the highly accurate wavelength-by-wavelength method of comparison (Figure 1). This minimizes the errors associated with setting the lamp current, distance, wavelength and repeatability.

In this technique, both lamps (standard and test) are operated at the same distance. The spectral irradiance of both lamps is measured at a set wavelength by translating the double monochromator along the optical bench to view each source. A wavelength-by-wavelength comparison is made at all of the NIST calibration wavelengths.

The high-accuracy standards are calibrated by comparison to a standard that was calibrated directly against a NIST standard.

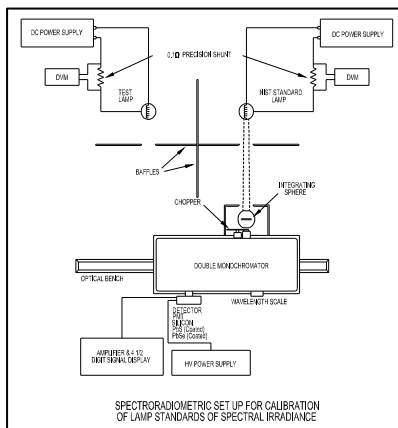

Optional Accessories

- OL 56 Lamp Holder
- OL 63 Adjustable Lamp Holder Mount
- OL 83A Programmable Current Source

Optional Accessories

Gooch and Housego offers several accessories to enable the user to realize the high accuracy assigned to its NIST-traceable standards. These accessories are designed to minimize errors due to current setting, alignment and orientation.

The OL 83A Programmable Current Source is specifically designed for operating the lamp standards at the exact calibration current.

There are six dimensional variables involved in the NIST recommended alignment of a lamp relative to the instrument. The OL 56 Lamp Holder and OL 63 Adjustable Lamp Holder Mount (Figure 2) are designed to allow the user to control the physical positioning of the lamp including distance, horizontal and vertical distance off the optical axis, pitch (tilt), yaw (rotation) and roll.

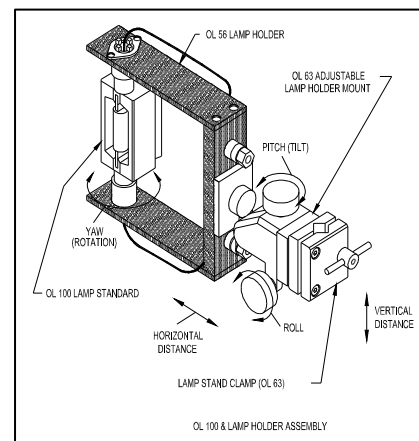

Contact: sales@goochandhousego.com

www.goochandhousego.com

As part of our policy of continuous product improvement, we reserve the right to change specifications at any time